

(IN)finito

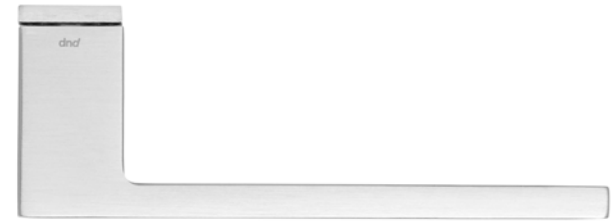

Come un filo bidimensionale che arriva dai bordi della porta, disegna la maniglia e poi continua il suo viaggio, ora verso l'altro lato, ora verso l'alto, ora nell'altra direzione.

Like a two-dimensional line that arrives from the edges of the door and draws the handle before continuing on its way, towards the other side, upward, in the opposite direction.

 **Selezionato
ADI DESIGN 2019**
Selected for
ADI DESIGN 2019

(IN)finito

design:
Alfonso Femia

made in italy



IF10
ONO

Ottone stampato a caldo
Hot stamped brass



OLV new
Lucido
Polished



AB new
Bronzato
Antique bronze



SO new
Sabbiato opaco
Matt sandblasted



PCS
Power cromo satinato
Power satin chrome



ONO
Nero
Black



Selezionato ADI DESIGN 2019
Selected for ADI DESIGN 2019

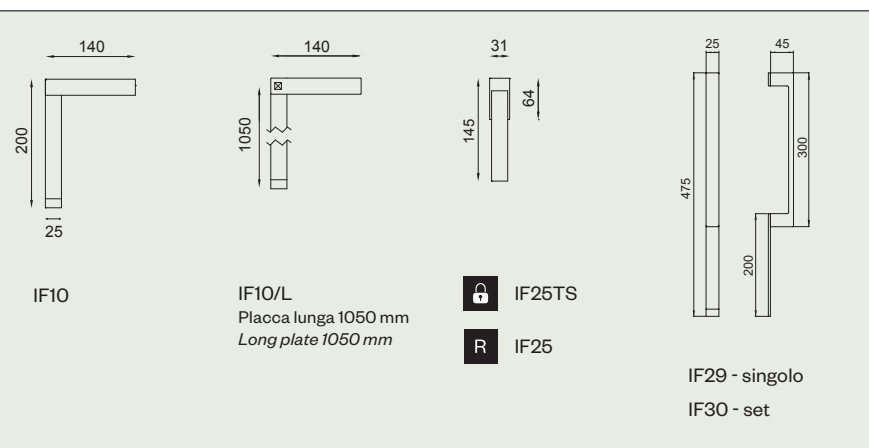



Il modello di maniglia
si declina in diverse
soluzioni.

*The door handle
model comes in
different versions.*

La rosetta diventa
un elemento minimo
e si innesta alla base
della maniglia.

*The rose becomes a
minimal element and
gets in position at the
handle base.*

(IN)finito

design:
Alfonso Femia

made in italy



IF01
PCS

098-

dnd22-23

new 2022

Ottone stampato a caldo
Hot stamped brass



OLV new
Lucido
Polished



AB new
Bronzato
Antique bronze



SO new
Sabbiato opaco
Matt sandblasted



PCS
Power cromo satinato
Power satin chrome



ONO
Nero
Black

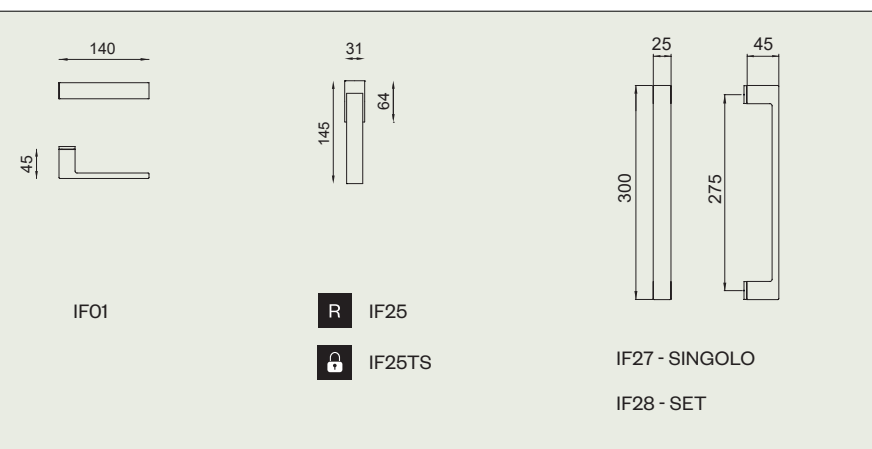

099



La placca riprende
il profilo della maniglia,
si fa sottile e si adatta
orizzontalmente alla
superficie della porta.

*The plate is shaped
like the door handle,
it becomes thin and
conforms horizontally
to the door surface.*

(IN)finito

design:
Alfonso Femia

made in italy



IF11
OLV

dnd22-23

new 2022

Ottone stampato a caldo
Hot stamped brass



OLV new
Lucido
Polished



AB new
Bronzato
Antique bronze



SO new
Sabbiato opaco
Matt sandblasted



PCS
Power cromo satinato
Power satin chrome



ONO
Nero
Black

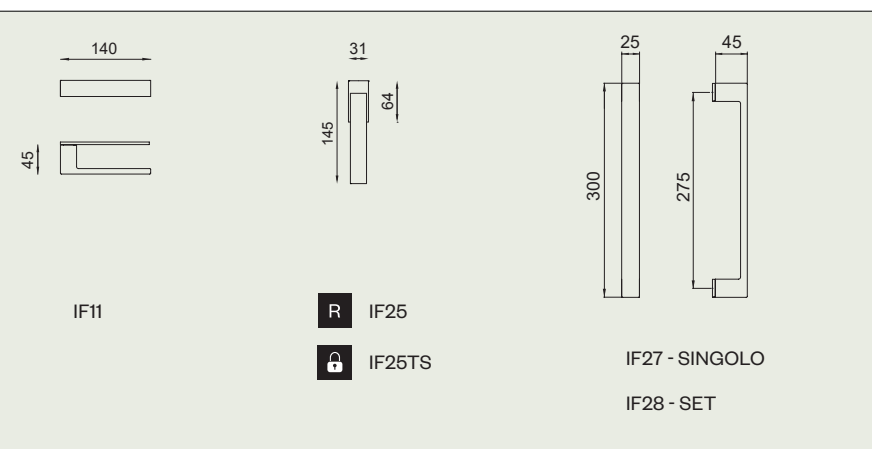

(IN)finito

design:
Alfonso Femia

made in italy

Ottone stampato a caldo
Hot stamped brass

new 2022



OLV new
Lucido
Polished



AB new
Bronzato
Antique bronze



SO new
Sabbiato opaco
Matt sandblasted



PCS
Power cromo satinato
Power satin chrome



ONO
Nero
Black

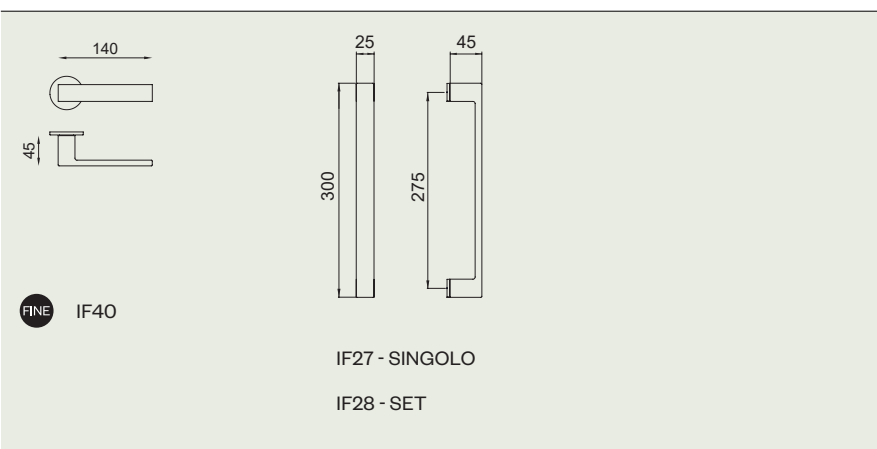

IF40
PCS

104-

dnd/22-23

105

(IN)finito

design:
Alfonso Femia

made in italy



IF41
ONO

Ottone stampato a caldo
Hot stamped brass

new 2022



OLV new
Lucido
Polished



AB new
Bronzato
Antique bronze



SO new
Sabbiato opaco
Matt sandblasted



PCS
Power cromo satinato
Power satin chrome



ONO
Nero
Black

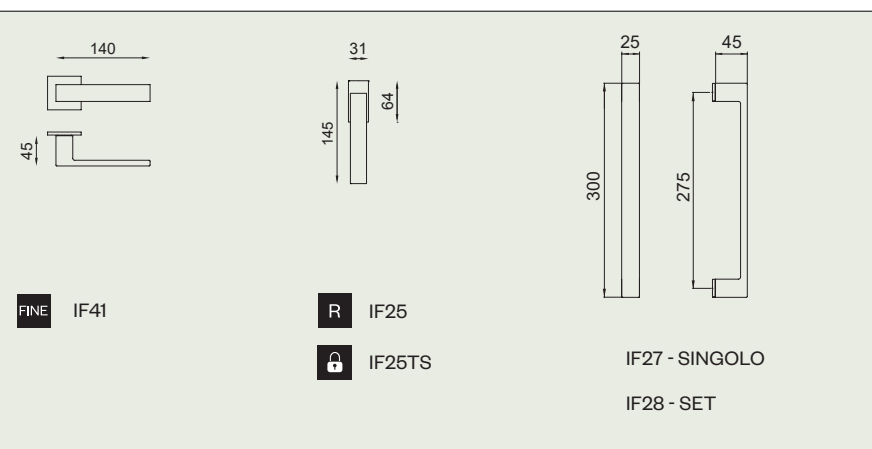

Alfonso Femia



Originario di Taurianova (RC), vive tra Genova, Milano e Parigi. Laureato presso la Facoltà di Architettura dell'Università di Genova nel 1992, è iscritto all'Ordine degli Architetti di Genova, dell'Île-de-France e della Svizzera. Ha insegnato Progettazione Architettonica alla Kent State University di Firenze, alla Facoltà di Architettura di Ferrara e a quella di Genova. Fondatore di 5+1 nel 1995, crea 5+1AA nel 2005 e 5+1AA Parigi nel 2007. Tra i suoi progetti, la nuova sede BNP Paribas a Roma, i Docks di Marsiglia, le OGR di Torino.

Born in Taurianova (RC), he lives between Genoa, Milan and Paris. With a degree from the School of Architecture of the University of Genoa in 1992, he is a member of the Architects Associations of Genoa, Île-de-France and Switzerland. He has taught Architectural Design at Kent State University in Florence, and the Schools of Architecture of Ferrara and Genoa. He was a founder of 5+1 in 1995, and created 5+1AA in 2005 and 5+1AA Paris in 2007. His projects include the new BNP Paribas headquarters in Rome, the Docks of Marseille, the OGR in Turin.



Nuova Biblioteca, La Spezia/Italy (2012-2016)



BNL-BNP Paribas Headquarters, Roma/Italy (2012-2017)



(IN)finito
Disegni della maniglia di /
Handle sketches by
Alfonso Femia



I Giardini di Gabriel, Asnières-sur-Seine/France (2013-2016)



Marseilles Docks, Marseille/France (2009-2015)